



The Mercedes-Benz eVito.

Model information & price list.

Prices effective from January 2020.

Mercedes-Benz





Contents

> Keeping businesses moving	3
> Delivering our promise	4
> The new eVito	5
> Why switch to electric?	6
> The essentials	7
> Charging and connectivity	8
> Mercedes PRO connect	9
> Are you #eReady?	10
> Choose your eVito	11
How to select your van	11
Trims	12
Colours and trim	14
Wheels	15
> Engine & gearbox	16
> Range, performance and CO ₂ emissions	17
> Weight & payloads	17
> Dimensions	18
> List prices	20
> Equipment overview – standard and optional	21
> Mercedes-Benz Finance	28

Please note

This document provides information about the model range line-up and specifications of the eVito. It also contains key details about options, economy and performance of all variants. Details are correct at time of publication and are subject to revision. Any images used in this document may not reflect UK specification and are for illustrative purposes only. Images may show optional equipment which does not form part of UK standard specification.

Mercedes-Benz Vans. Keeping businesses moving.

The most driven businesses drive Mercedes-Benz vans.
Why? Because we keep them moving...

From delivery firms to dog walkers, supermarkets to safety engineers, paramedics to photographers, and international couriers to local chefs, the people we support are hardworking, self-assured, forward-looking, and hardwired to succeed. And they all share a desire to keep moving.

These businesses also share an interest in the future – and certainly don't want to get left behind when it comes to using electric vehicles. That's why we've worked hard to develop the UK's first mid-sized fully electric van, ensuring it's as reliable and technically advanced as its siblings. It's yet another example of how we go further to support our customers' businesses and maximise vehicle uptime.

We're your business partner, not your vehicle supplier. We're with you all the way. And we won't stop, because we know you can't afford to.



The Mercedes-Benz eVito

Delivering on our promise to keep you moving.

- **Industry-leading quality** – We keep innovation moving. Mercedes-Benz Vans are one of the leading brands when it comes to the development and production of electric vehicles. And we also invest £4.63bn in R&D each year to make sure we continue to lead the field in safety too.
- **Flexible, accessible finance solutions** – We keep your cash flow moving.
- **Quality assured Approved Used vans** – We keep all businesses moving. Our Approved Used vans remove all barriers to Mercedes-Benz quality without compromising on our exacting standards.
- **Free roadside assistance** – Every single Mercedes-Benz van comes with a lifetime promise to keep you moving, no matter what: MobiloVan – free dedicated roadside assistance for 30 years*.
- **24/7 servicing** – We keep your working day moving. Over a third of our Dealer Network works through the night to service and maintain our customers' vans, so they're out on the road during the day, earning their keep.

*For a full list of exclusions and all product terms please visit mbvans.co.uk/mobilovan

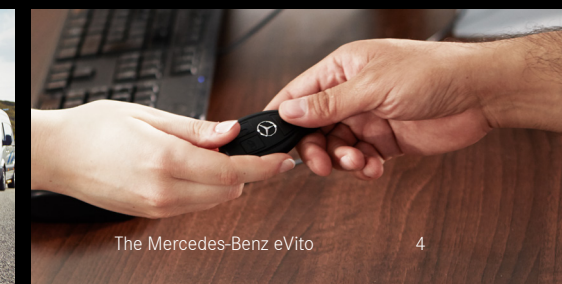

The Mercedes-Benz eVito

The new 100% electric eVito.

Everything you'd expect from Mercedes-Benz Vans – electrified.

With an average range of 93 miles on one charge†, generous payload and cargo capacity, and Mercedes PRO connect technology to help optimise routes and extend range, the Mercedes-Benz eVito is here to keep your business moving more efficiently and sustainably.

The vehicle's two trims – PURE and PROGRESSIVE – make it easier than ever to specify the features and functionality your business needs. With impressive whole of life costs and free 24/7 MobiloVan roadside assistance*, you'll have everything you need to raise your game.

Don't let anything hold your business back.

A wealth of innovations and safety features as standard, coupled with incredible versatility: the Mercedes-Benz eVito is so much more than a mid-size van. There's a choice of two vehicle lengths, a variety of colour options and uncompromised loading space.

Let us help you find an eVito that works for you...



The Mercedes-Benz eVito: lower costs, lower impact

- **Lower running costs** – versus petrol or diesel
- **Lower servicing costs** – electric-powered engines are easier to maintain
- **Lower purchase price** – thanks to Government plug-in grants
- **Zero road tax** – helping you reduce operational costs
- **Exemption from urban congestion charges** – making work in the city even simpler.

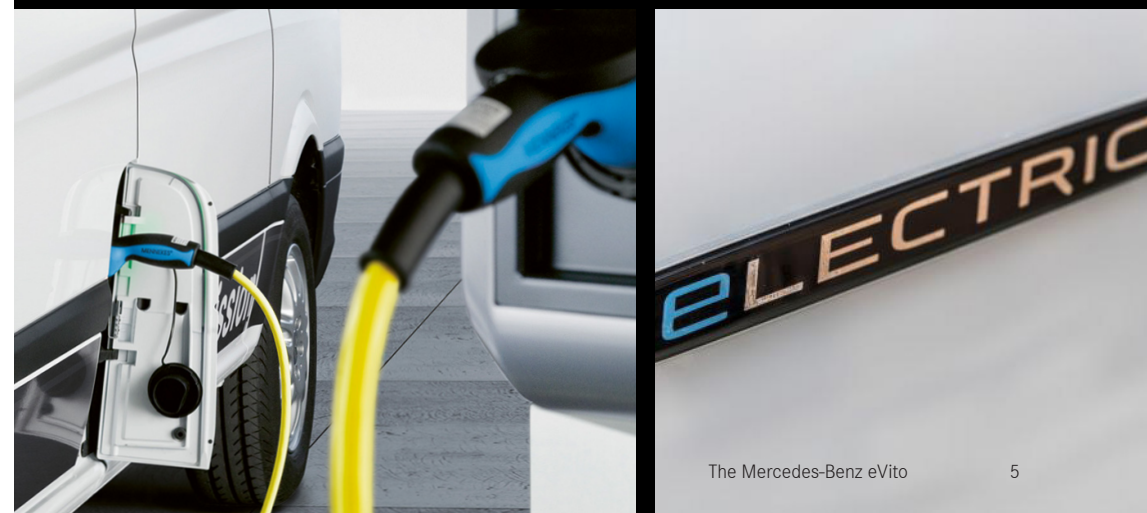

†According to the Worldwide Harmonised Light Vehicle Test Procedure (WLTP).

* Renewed at each service if serviced by MB according to service intervals.

For a full list of exclusions and all product terms please visit mbvans.co.uk/mobilovan

Why switch to electric?

The Mercedes-Benz eVito delivers efficiency, reliability, functionality and more.

As one of the leading manufacturers of commercial vehicles, you can feel reassured that your move into the world of electric-powered vans with Mercedes-Benz will be seamless – and there are multiple benefits to switch from petrol or diesel.

Efficiency

Choosing an eVito could start to pay off straight away. Depending on how you use it, the highly efficient electric drive means the eVito can already match the total cost of ownership of a diesel or petrol van. You can also maximise your cost savings by taking advantage of lower overnight charging costs and by optimising power consumption while driving.

Reliability

The eVito is as hard working as it is innovative. The electric drive and heating have passed our comprehensive winter test with temperatures as low as -30°C . It has extensive corrosion protection with a fully galvanised body, so it will continue to look good after years on the road.

Functionality

The eVito has the upper hand when it comes to cargo. As the electric drive and batteries are housed in the underbody of the vehicle, they don't take up any space in the cargo area. The Long version has a maximum payload of up to 923kg and up to 6m^3 loading space and the Extra Long version can carry 898kg in its generous 6.6m^3 space. With the large door openings and low sill, you can handle even the most difficult loading and unloading tasks with ease.



eVito: the essentials.

The Mercedes-Benz eVito delivers better performance than you might imagine.

› Range: 93 miles on average*

The average driving range of the eVito is 93 miles*, however this can be extended or reduced depending on the driving mode you choose:

- C Extended comfort & agility could lead to significantly reduced range
- E Optimised efficiency leads to the certified range
- E+ Extended range leads to maximum range.

To maximise battery performance, the eVito uses a process called recuperation that recovers energy when the vehicle is decelerating. You can adjust the recuperation mode with the gearshift paddles and the greater the recuperation, the faster you decelerate.

- D- The maximum deceleration, activating your brake lights (-1.5m/s²††)
- D Normal deceleration (-1.0 m/s²††)
- D+ Low levels of deceleration (0.5m/s²††)
- D++ Sailing 0 m/s²††.

› Payload: up to 923 kg

The eVito has generous cargo space, as its batteries are positioned in the underbody of the vehicle. And the Long wheel base edition has a payload of up to 923 kg, a capacity to match the demands of everyday working life.

› Charging time: from 6 hours

- 6 hours* using the Wallbox Type 2: (2 x 16 A | 7.2 kW)
- 20 hours* using a regular power outlet: (1 x 10 A | 2.3 kW).

› Battery: 70%+ capacity after 8 years

- The battery has a warranty and after 8 years, it's capacity is expected to be at least 70%
- Three parallel high-voltage battery blocks are installed in the eVito's underbody. In case of damage they can be replaced individually.

*According to the Worldwide Harmonised Light Vehicle Test Procedure (WLTP)

**Real recuperation/deceleration depends on multiple factors e.g. driven speed, overall vehicle weight. These figures show the maximum deceleration possible.

†Brake lights when recuperation/deceleration is activated and the vehicle is slowing.

Getting more from your eVito.

> Charging¹

Charging the Mercedes-Benz eVito is easier than you think – and we'll make sure your charging set-up is just right for your business, depending on your unique needs.

- **Planning and installation** – from a single Mercedes-Benz Wallbox, to a bespoke system for multiple vehicles, you'll always be ready to power up your vans
- **Ease of operation** – choose a 4-metre or 8-metre charging cable and it's easy to charge your battery at a Wallbox or charging station
- **Increasing range** – with three different driving programs and energy recuperation, you can adapt your driving style to maximise your battery range.

> Connectivity

With Mercedes PRO connect², you can manage your vehicle via your mobile or desktop with remote charging, fleet connectivity and real-time vehicle information such as battery range (for more information on Mercedes PRO connect, see [p.9](#)).

- **Cost reduction** – remote eCharging¹ means you can stagger your fleet charging overnight and save through lower energy tariffs
- **Driver comfort** – with online access, your drivers can set a pleasant cabin temperature via the mobile app before you set off
- **User management** – view charging history, authentication and assign charging processes to users and vehicles.

¹ If you are planning to charge your Mercedes-Benz plug-in electric vehicle using a 3-pin domestic plug socket you must get a qualified electrician to inspect and sign off the socket to confirm it is safe and suitable to charge your vehicle.

Do not use an electric vehicle 3-pin charge cable with an extension cord.

² Mercedes PRO connect is available for eVito vehicles manufactured as of 03/2019.

Please speak to your preferred Dealership to ask about the availability of Mercedes PRO connect services.

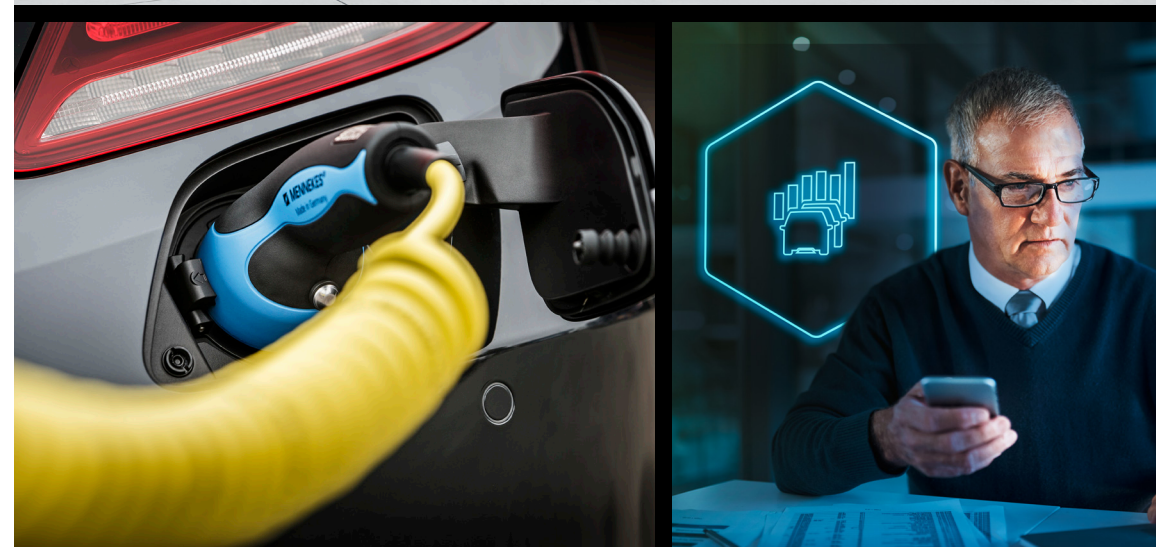

Mercedes PRO connect: electric at your fingertips.

Get more from your vehicles than ever before with Mercedes PRO connect.

The eVito comes with Mercedes PRO connect as standard, with most features free for 2 years. As well as helping you improve fleet communication, and remotely monitoring repairs and servicing requirements, Mercedes PRO connect offers dedicated electric features such as locate a charge station, optimise route planning, remotely check the charge status of your vehicle and pre-condition the cabin temperature ahead of your journey.

Intelligence, communication and more

› More efficiency

Assign tasks, track jobs and contact your drivers at the touch of a button. Keep your vans on the road for as long as possible with Optimised Assistance – intelligent software which gives you real-time reports of critical parts.

› More security

Protect your vehicles with theft warning alerts, live locking from your mobile and use geofencing to alert you when your vehicles leave a defined area.

› More safety

Keep your drivers safe with Accident & Breakdown Management, hands-free multimedia functions and live traffic information. Monitor driving styles to get a clear picture of your drivers' performance.

To learn more about the benefits of Mercedes PRO connect, please visit:
<https://www.mercedes-benz.co.uk/vans/en/mercedes-pro-connect>



Are you #eReady?

Take a virtual test drive with our eVAN Ready App.

Before you invest in an electric van, you'll probably have questions like, "how much range do I really have?" and "how often will I need to charge it to make sure the battery won't run out?". Our eVAN Ready app can help you find the answers.

Simply download on your mobile and it will automatically record your journeys as you travel around in your existing vehicle. For each journey, it will analyse your distance, driving and braking behaviour, as well as the altitude profile of your trip. The app will then calculate the virtual range and battery capacity needed with an electric vehicle and tell you if you could have made the same trip in one of our electric vans.

It takes seconds to set up, so download it for Apple or Android now.

Need further help?

When switching to a brand-new way of powering your business, it's only natural you'll have questions. So, if there's anything you'd like to find out that's not covered in this brochure, then feel free to take a look at <https://www.mercedes-benz.co.uk/vans/en/e-vito-panel-van> or find your local Dealer using our Dealer locator tool: <https://www.mercedes-benz.co.uk/vans/en/content-pool/apps/dealer-locator>

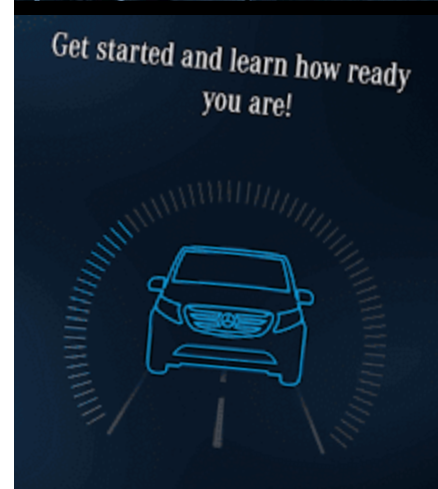

The Mercedes-Benz eVito

Choose your eVito

Step 1: How to select your van

eVito Panel Van

Built to work hard for your business

The eVito Panel Van's incredible versatility and easy loading capabilities support businesses of all shapes and sizes. With two lengths to choose from, there's an eVito Panel Van to carry your cargo, no matter what the requirement. Plus, there's a wide range of options to enhance your driving experience, security and safety too.

Vehicle Exterior Dimensions - L2 and L3



1. Consider the kind of loads and cargo you'll be carrying and then decide which trim is right for you. PURE or PROGRESSIVE.
2. Choose a colour and paint type – standard or metallic – and select an upholstery trim that best meets your needs.
3. You can choose to upgrade your wheels if you like – we've a selection of alloy and steel wheels.
4. Review the eVito's technical information to ensure it meets all of your business's requirements.
5. Review the range of standard equipment in each trim or choose to enhance and further style your eVito from our range of optional equipment and packages available.

Choose your eVito

Step 2: Which trim is right for you?

PURE

The PURE trimline is all about keeping you moving in safety and comfort:



Audio 10 infotainment system



Height and rake adjustable steering wheel



Comfort driver's seat



Twin sliding doors

Interior features

- Height and rake adjustable steering wheel
- Full-width partition
- Audio 10 infotainment system
- Locking glove compartment
- Comfort overhead control panel
- 2-way loudspeakers in the front
- Spare wheel with jack
- Multi-button remote control
- Semi-automatic TEMPOMATIC air conditioning
- Cleaning fluid level warning light
- Communication module (LTE) for digital services
- Tyre pressure monitoring front/rear, wireless
- Heated seat for driver
- Airbag, co-driver
- Comfort driver's seat
- Co-driver's double seat
- Weld nuts in the sidewall for conversions
- Fixing points in the roof frame
- Mercedes PRO connect features as standard
- CanTrack – vehicle tracking module
- Interior panelling in load compartment
- Wood flooring
- Headlight Assistant - auto on/off

Exterior features

- Aerodynamic underbody panelling
- Hill-Start Assist
- Heated, electrically adjustable exterior mirrors
- Heat-insulating glass
- Adaptive brake light
- Sliding door left and right
- Rear door without window, double-wing, 180°
- Wallbox/charging station cable, Type 2 (Mode 3) 4m.



Price:
Starting from £39,895*

*Based on a eVito Van PURE L2 FWD.
For full pricing, see page 20.

Choose your eVito

Step 2: Which trim is right for you?

PROGRESSIVE

The PROGRESSIVE trimline includes all of the features found on the eVito PURE – plus the following features to build on the distinctive styling, improve drive experience and enhance safety:



Colour-coded bumpers



Audio 15 infotainment system



Headlight Assistant



Electrically folding mirrors

Interior features

- Audio 15 infotainment system
- Speed limited to 75 miles per hour
- Driver's seat lumbar support

Exterior features

- Metallic paint
- Colour-coded front & rear bumpers
- Electrically folding exterior mirrors
- Front fog lamps
- 17-inch full wheel cover.



Price:
Starting from £41,600*

*Based on a eVito Van PROGRESSIVE L2.
For full pricing, see page 20.

Choose your eVito

Step 3: Colours and trim

Make a statement with your eVito. A wide range of paints and finishes provide an ideal backdrop to your business's promotional livery, while the rugged, stylish black upholstery is comfortable and easy to clean. Take a look at the paint and colour options available – including standard and metallic finishes – and select a trim material that best suits your needs.

Interior trim



Black Tunga seats

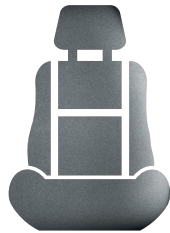

Black Man-made leather seats

> [For pricing, see page 22](#)

Standard paints



Arctic white



Pebble grey



Jupiter red



Navy blue



Granite green

Metallic paints



Brilliant silver



Dark graphite grey



Selenite grey



Obsidian black



Cavansite blue



Hyacinth red

Choose your eVito

Step 4: Wheels

Our wide range of wheels mean you can finish off your eVito in style. Our designs combine functionality with flair to give your chosen model a look that's distinctively Mercedes-Benz.

1. 17-inch Alloy Wheels with a 20-spoke design (RK8)
225/55 tyres
2. 17-inch Full Wheel for steel wheels (RD8)



Engine and gearbox

	PURE / PROGRESSIVE
Engine specifications	eVito
Fuel	Electric
Output, max.	114hp
	85kW
	116PS
Range	93miles*
Torque, max.	295Nm
Driven Axle	Front
Battery Composition	Lithium Ion
Battery Capacity	41kWh (35kWh useable)
Battery Voltage	365
Battery Charging	7.4kW
Battery Charging Time	6hours (Wallbox)
Charging cable	4m long - Type 2*

*According to the Worldwide Harmonised Light Vehicle Test Procedure (WLTP).

Range, performance and CO₂ emissions

Panel Van

Category	Model	CO ₂ emissions (g/km)	Combined	WLTP Range (Miles)				WLTP Range (Km)				
				Low (Extra Urban)	Medium (Urban)	High (Rural)	Extra High (Motorway)	Combined	Low (Extra Urban)	Medium (Urban)	High (Rural)	Extra High (Motorway)
PURE	eVito Van PURE L2	0	93.0	104.0	104.0	95.0	81.0	149.0	167.0	167.0	153.0	130.0
	eVito Van PURE L3	0	92.0	103.0	103.0	95.0	81.0	148.0	166.0	166.0	153.0	130.0
PROGRESSIVE	eVito Van PROGRESSIVE L2	0	92.0	103.0	103.0	95.0	81.0	148.0	166.0	166.0	153.0	130.0
	eVito Van PROGRESSIVE L3	0	91.0	102.0	102.0	94.0	81.0	147.0	164.0	164.0	152.0	130.0

All figures are based on a standard specification.

The choice of wheels and transmission may affect CO₂ emissions.

The indicated values were determined according to the prescribed measurement method - Worldwide Harmonised Light Vehicle Test Procedure (WLTP). Figures shown may include options which are not available in the UK. For Battery Electric Vehicles (BEV) figures determined with battery fully charged.

These models require mains electricity for charging. Figures shown are for comparability purposes; only compare with other vans tested to the same technical procedures. Figures may not reflect real life driving results, which will depend upon a number of factors including the starting charge of the battery, factory-fitted options, accessories fitted (post registration), variations in weather, driving styles and vehicle load. Further information about the test used to establish fuel consumption and CO₂ figures can be found at <http://www.mercedes-benz.co.uk/WLTP>

Weights and payloads

PURE - Panel Van

Model	Gross Vehicle Weight (Kg)	Unladen Weight (Kg)	Payload (Kg)	Gross Train Weight (Kg)
eVito Van PURE L2	3,200	2,277	923	3,200
eVito Van PURE L3	3,200	2,302	898	3,200

Please note: The stated payload weights are correct according to type approval data. The specific payload values for UK supplied vehicles may differ. The figure quoted only accounts for equipment which is included in the UK product offer as standard. Please speak to a dealer for final vehicle configurations and weights once all options and accessories have been added.

PROGRESSIVE - Panel Van

Model	Gross Vehicle Weight (Kg)	Unladen Weight (Kg)	Payload (Kg)	Gross Train Weight (Kg)
eVito Van PROGRESSIVE L2	3,200	2,295	905	3,200
eVito Van PROGRESSIVE L3	3,200	3,200	890	3,200

Panel Van dimensions L2

	Description	L2
Wheelbase	Wheelbase length	3,200mm
	Turning circle	11.8m
	Track circle	11m
	Front track width	1,666mm
	Rear track width	1,646mm
Vehicle	Length	5,140mm
	Height (unladen)	1,948mm
	Width (inc. wing mirrors)	2,249mm
	Ground clearance	116mm
Load compartment	Length	2,831mm*
	Load volume	6.0m ³
	Max. width	1,685mm
	Width between wheel arches	1,270mm
	Height	1,391mm
	Rear loading height (step height from ground to load floor)	558mm

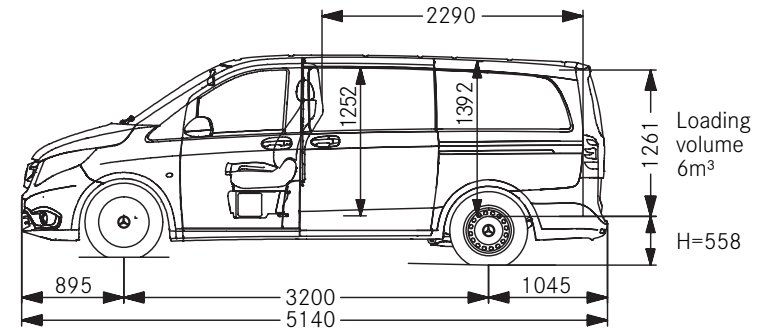
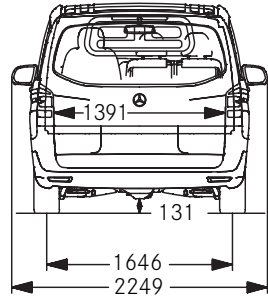
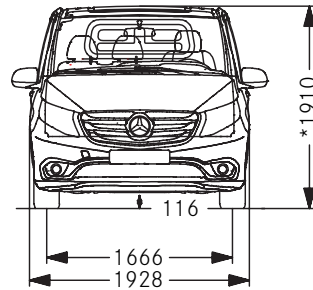

Loading volume 6m³
H=558

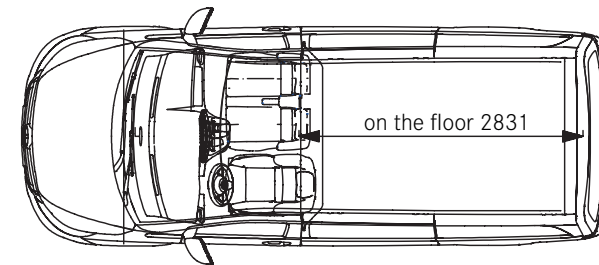

H ca. / *558 *unloaded
Turning circle Ø ca. 11.8m
Track circle Ø ca. 11m

*Measured on vehicle floor and includes 370mm for the space beneath the front seats.

Panel Van dimensions L3

	Description	L3
Wheelbase	Wheelbase length	3,430mm
	Turning circle	12.5m
	Track circle	12m
	Front track width	1,666mm
	Rear track width	1,646mm
Vehicle	Length	5,370mm
	Height (unladen)	1,948mm
	Width (inc. wing mirrors)	2,249mm
	Ground clearance	116mm
Load compartment	Length	3,061mm*
	Load volume	6.6m ³
	Max. width	1,685mm
	Width between wheel arches	1,270mm
	Height	1,391mm
	Rear loading height (step height from ground to load floor)	558mm

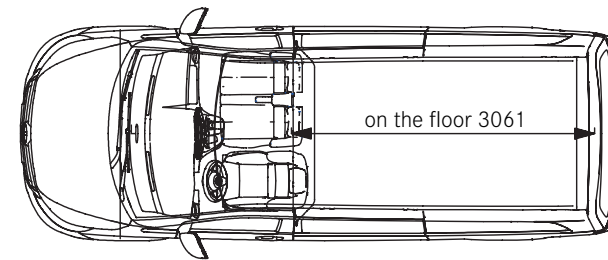
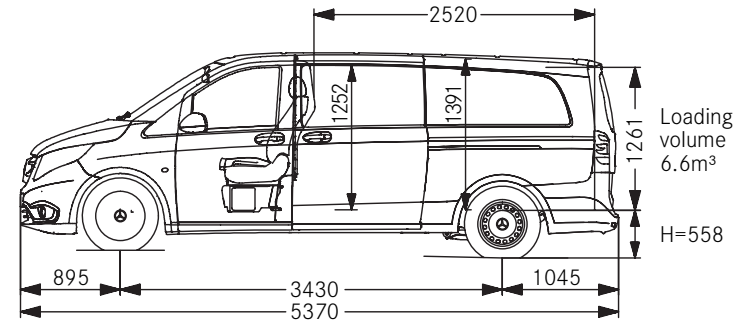
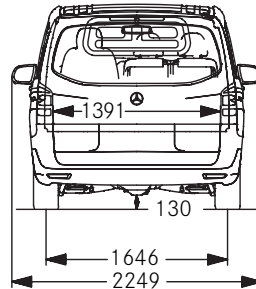
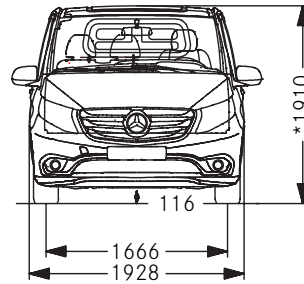

H ca. / *558 *unloaded
 Turing circle Ø ca. 12.5m
 Track circle Ø ca. 12m

*Measured on vehicle floor and includes 370mm for the space beneath the front seats.

List prices

PURE - Panel Van

Model	Drive	Basic Recommended Retail Price (Ex. VAT) £	Basic Recommended Retail Price (Inc. VAT) £
eVito Van PURE L2	FWD	£39,895	£47,982
eVito Van PURE L3	FWD	£40,415	£48,498

PROGRESSIVE - Panel Van

Model	Drive	Basic Recommended Retail Price (Ex. VAT) £	Basic Recommended Retail Price (Inc. VAT) £
eVito Van PROGRESSIVE L2	FWD	£41,600	£49,920
eVito Van PROGRESSIVE L3	FWD	£42,120	£50,544

This document is for guidance only and must be used in conjunction with a configuration tool prior to final specification decisions and vehicle quotations being prepared and accepted. List prices are quoted ex-factory and exclude VAT unless otherwise stated. Delivery charges excluding VAT may be added to model prices quoted in this document. Prices based on standard finish paint choice. Mercedes-Benz Vans UK and authorised Dealers reserve the right to alter specification and vary prices without notice. The availability of options may depend on the chosen base vehicle and other optional equipment specified, and should be confirmed with your Mercedes-Benz Vans Dealer prior to order placement.

Choose your eVito

Step 5: Equipment - standard and optional overview

Every eVito model comes with a host of standard features, plus a range of optional equipment and packages you can add to enhance your van.

Over the next few pages, you'll see an overview of all the equipment and packages using the following key to highlight if they are standard, optional, equipment dependant or unfortunately, not available.

Key: ● Standard ○ Optional ◇ Equipment dependant option available – Not available

Equipment	Description	Option code	PURE	PROGRESSIVE	Basic Price exc. VAT	Basic Price inc. VAT
			Panel Van	Panel Van		
Exterior Features						
Bodywork	Carrier bars	D15	○	○	£150.00	£180.00
	Chrome radiator grille Only available in conjunction with painted bumpers (CM2).	FK2	○	○	£110.00	£132.00
	Roof rails Maximum load of 150 kg, when supported by three carrier bars.	D12	○	○	£380.00	£456.00
Paint	Bumpers can be painted The surfaces have been pre-treated so the bumpers can be painted in the desired colour at a later date.	CM3	○	○	£115.00	£138.00
	Colour-coded front & rear bumpers	CM2	○	●	£315.00	£378.00
	Metallic paint	/	○	●	£565.00	£678.00
Tyres	Mud and slush tyres The M+S tyres can improve traction and lateral support in wintry road conditions, improving driving safety on snow, ice and mud.	RM1	○	○	£145.00	£174.00
	Summer Tyres		●	●	£0.00	£0.00
Wheels	17" Steel wheels Wheel: 6.5 J x 17 ET 51 Tyres: 225/55 R17.	RS7	●	○	£425.00	£510.00
	17" Full wheel cover	RD8	○	●	£80.00	£96.00

Changes to individual option availability and combinations may occur depending on vehicle specification choices and the continuing evolution and adaptation of our product range. These changes may not be immediately reflected in this document as they occur, but will be introduced at the next revision opportunity.

Choose your eVito

Step 5: Equipment - standard and optional overview

Equipment	Description	Option code	PURE Panel Van	PROGRESSIVE Panel Van	Basic Price exc. VAT	Basic Price inc. VAT
Wheels	17" Alloy wheels (20 spoke design) Painted in vanadium silver Wheel: 7 J x 17 ET 51 Tyres: 225/55 R 17.	RK8	○	○	£950.00	£1,140.00
Interior Features						
Flooring	Velour floor mats The black velour floor mats visually enhance the cockpit and underscore the elegant, sporty wellness ambience in the vehicle.	VL2	○	○	£45.00	£54.00
Grab Handles	Grab handles for driver's and co-driver's doors	T75	○	○	£45.00	£54.00
Heating and Ventilation	Heated driver's seat	H16	●	●	£0.00	£0.00
	Heated co-driver's seat	H15	○	○	£140.00	£168.00
	Pollen filter The pollen filter keeps even the smallest of particles out of the interior and can therefore protect against allergic reactions.	HF2	○	○	£40.00	£48.00
	TEMPMATIC air conditioning Cools and dehumidifies the air. Features a particulate filter to remove particles of dust and pollen from the outside air.	HH9	●	●	£0.00	£0.00
Seating	Comfort driver's seat Single armrest on the side facing the front passenger; fore/aft adjustment (225mm in total, with 4.5mm intervals); stepless adjustment of the seat backrest angle; stepless seat height adjustment; comfort head restraint adjustable for angle and height.	SB1	●	●	£0.00	£0.00
	Comfort co-driver's seat Comfort driver and co-driver seat with inboard armrests and 4-way adjustable headrests. This deletes the double co-driver seat and therefore limits the cab area to two occupants.	SB2	○	○	£85.00	£102.00

● Standard ○ Optional ◇ Equipment dependant option available – Not available

The Mercedes-Benz eVito

22

Choose your eVito

Step 5: Equipment - standard and optional overview

Equipment	Description	Option code	PURE	PROGRESSIVE	Basic Price exc. VAT	Basic Price inc. VAT
			Panel Van	Panel Van		
Seating	Double co-driver seat Bench seat with 2x three-point seat belts, height-adjustable head restraints, and a fixed 17° backrest.	S23	●	●	£0.00	£0.00
	Driver's seat plus with level sitting surface	SF3	○	○	£140.00	£168.00
	Co-driver seat plus with level sitting surface	SF4	○	○	£140.00	£168.00
	Lumbar support for driver's seat Electropneumatically operated dual-cushion 4-way lumbar support, adjusted using a switch on the outer side of the seat cushion. The position of the air cushions can also be adjusted for height.	SE5	○	●	£105.00	£126.00
	Lumbar support for co-driver's seat Not compatible with Double co-driver seat (S23).	SE4	○	○	£105.00	£126.00
Steering Wheel	Height and rake adjustable steering wheel Manually adjustable by 4.8° in tilt and 60mm in/out.	CL1	●	●	£0.00	£0.00
Storage	Centre console with stowage compartment	FF1	○	○	£65.00	£78.00
	Locking glove compartment Lock operated using the manual emergency key which is integrated within the electronic ignition key.	F66	●	●	£0.00	£0.00
Trim and Upholstery	Black Tunja seat upholstery	VY2	●	●	£0.00	£0.00
	Black leatherette seat upholstery The black man-made leather lends the interior a comfortable aspect and impresses with its low-maintenance surface.	VU9	○	○	£90.00	£108.00
Technology, Software & Electrics						
Audio Entertainment	Audio 10 Monochrome 8.9cm (3.5-inch) display; Bluetooth® hands-free phone and audio connection; FM/AM (MW); USB/aux-in/SD-card inputs.	EN6	●	-	£0.00	£0.00
	Audio 15 5.8cm (2.3 inches) Colour TFT display; Bluetooth® compatible for handsfree phone and audio playback; USB, AUX-in, SD-card inputs; FM/AM radio tuner.	EN7	○	●	£620.00	£744.00

● Standard ○ Optional ◇ Equipment dependant option available – Not available

The Mercedes-Benz eVito

23

Choose your eVito

Step 5: Equipment - standard and optional overview

Equipment	Description	Option code	PURE Panel Van	PROGRESSIVE Panel Van	Basic Price exc. VAT	Basic Price inc. VAT
Audio Entertainment	Audio 40 The 7.8cm (7 inch) touchscreen and integral navigation offers versatile and intuitive communications and infotainment options. The indications and displays of the navigation with 3D city views and landmarks are attractive and easy to understand. Further highlights include the digital radio DAB+, Smartphone Integration via Apple® CarPlay and Android Auto and also the Bluetooth® interface with audio streaming and hands-free function for making phone calls while driving with minimal distraction. Two USB interfaces allow the charging of mobile end devices in the vehicle, amongst other things.	EA4	○	○	£660.00	£792.00
Keys	Two additional master keys	FZ9	○	○	£105.00	£126.00
Driver's Assistance & Safety						
Airbags	Driver's airbag	/	●	●	£0.00	£0.00
	Co-driver airbag	SA6	●	●	£0.00	£0.00
	Driver thorax-pelvis sidebag	SH1	○	○	£195.00	£234.00
	Co-driver thorax-pelvis sidebag	SH2	○	○	£195.00	£234.00
Driver's Assistance	Active ESP The adaptive Electronic Stability Program can support the driver in critical driving dynamics situations by generating direction-stabilising brake forces.	BB9	●	●	£0.00	£0.00
	Comfort overhead control panel LED interior lighting including cab downlighting and co-/driver reading lamps; also includes a convenient spectacles compartment.	LC4	●	●	£0.00	£0.00
	Headlight assistant A windscreen sensor continuously monitors light conditions and automatically switches the dipped beams on/off upon reaching pre-defined limits.	LA2	●	●	£0.00	£0.00
	Jack	Y36	○	○	£55.00	£66.00
	Rain sensor The rain sensor automatically regulates the wiping frequency of the windscreen wipers with activated intermittent wiping, which makes things easier for the driver.	JF1	○	○	£110.00	£132.00

● Standard ○ Optional ◇ Equipment dependant option available – Not available

The Mercedes-Benz eVito

24

Choose your eVito

Step 5: Equipment - standard and optional overview

Equipment	Description	Option code	PURE	PROGRESSIVE	Basic Price exc. VAT	Basic Price inc. VAT
			Panel Van	Panel Van		
Driver's Assistance	Tyre pressure monitoring, wireless Monitors air pressure in all 4 wheels. Slight pressure variances generate a visual warning. Sudden, extreme pressure losses trigger an additional acoustic warning.	RY2	●	●	£0.00	£0.00
Parking	Reversing camera	FR8	○	○	£480.00	£576.00
	Reversing warning device The reverse warning alarm warns pedestrians and other road users audibly of the reversing vehicle and thereby enhances their safety.	JW0	○	○	£90.00	£108.00
Safety Equipment	Accident recovery and breakdown management The vehicle will automatically call the Mercedes-Benz Customer Assistance Centre at a press of a button to provide the driver with professional help in the event of an emergency.	EY6	●	●	£0.00	£0.00
	First aid kit	Y10	○	○	£45.00	£54.00
	Fire extinguisher 1kg	YF7	○	○	£120.00	£144.00
	PRE-SAFE The PRE-SAFE® anticipatory occupant protection system can detect critical driving situations at an early stage and initiate preventive protection measures.	JP1	○	○	£325.00	£390.00
	Warning Triangle	Y44	○	○	£45.00	£54.00
Security	Anti-theft protection package Thatcham category 1 approved. Cab interior and load-space monitoring with battery back-up siren and tow-away protection.	FY1	○	○	£320.00	£384.00
Lighting						
Lighting	Blinker lights behind on roof The additional turn signal lamps on rear of roof improve the visibility of the vehicle, thus enhancing perceptual safety.	L84	○	○	£135.00	£162.00
	Halogen front fog lights Controlled via a push button next to the steering wheel.	L16	○	●	£195.00	£234.00

● Standard ○ Optional ◇ Equipment dependant option available – Not available

The Mercedes-Benz eVito

25

Choose your eVito

Step 5: Equipment - standard and optional overview

Equipment	Description	Option code	PURE	PROGRESSIVE	Basic Price exc. VAT	Basic Price inc. VAT
			Panel Van	Panel Van		
Lighting	Interior and ambient lighting	LP1	○	○	£220.00	£264.00
	LED lightstrip in load compartment	LC2	○	○	£95.00	£114.00
Loading & Towing						
Bulkhead	Full-width partition The full-width bulkhead at B-pillar protects driver and front passenger from the load and shields the driver compartment from the load compartment, keeping dirt, dust and noise away from the driver's compartment.	D50	●	●	£0.00	£0.00
	Full-width partition with 1 window The full-width partition wall on the B-pillar with window allows a view into the cargo area or the view to the rear and shields the driver's compartment from the load compartment.	D51	○	○	£65.00	£78.00
Gross Vehicle Weight (GVW)	Gross vehicle weight 3.2T	XA5	●	●	£805.00	£966.00
Load Area	Interior wood panelling to roof height in load compartment The 5 mm-thick wooden panelling of the vehicle sidewalls extending up to roof height protects the sheet metal in the load compartment from damage caused by the cargo.	VA2	○	○	£280.00	£336.00
	Wood load flooring Multiple-bonded 10 mm thick weatherproof plywood floor, coated with hard-wearing phenolic resin film, and featuring a non-slip textured grid surface.	V43	●	●	£0.00	£0.00
Mirrors & Windows						
Mirrors	Electrically folding wing mirrors Fold-in/out function is operated via controls in the driver door.	F64	○	●	£190.00	£228.00
	Heated, electrically adjustable wing mirrors Mirror heating reduces condensation in cold weather and prevents icing-up of the mirrors. The exterior mirrors are heated automatically upon vehicle start when the outside temperature is low or when the rear defrost function is activated.	F68	●	●	£0.00	£0.00
Mirrors	Mirror package The eVito Mirror package uses automatically dimming mirrors and electrically folding outside mirrors to increase the driving comfort and driving safety.	FP2	○	○	£340.00	£408.00

● Standard ○ Optional ◇ Equipment dependant option available – Not available

The Mercedes-Benz eVito

26

Choose your eVito

Step 5: Equipment - standard and optional overview

Equipment	Description	Option code	PURE	PROGRESSIVE	Basic Price exc. VAT	Basic Price inc. VAT
			Panel Van	Panel Van		
Windows	Black-tinted windows in rear 90% window tint offers attractive thermal and privacy protection. Applies to all windows after the B-pillar.	W70	-	-	£0.00	£0.00
	Heat-insulating glass Windscreen (laminated glass), side windows and rear window (single-pane safety glass) are tinted green, reducing the sunlight's heating effect on the interior.	H20	●	●	£0.00	£0.00
	Sliding window in left sliding door	W18	○	○	£355.00	£426.00
	Sliding window in right sliding door	W19	○	○	£355.00	£426.00
Charging Accessories						
Cables	4m Spiral charging cable Type 2, 3x20A	E4L	●	●	£0.00	£0.00
	8m Charging cable Type 2, 3x32A	E9L	○	○	£0.00	£0.00

● Standard ○ Optional ◇ Equipment dependant option available – Not available

The Mercedes-Benz eVito

27

Mercedes-Benz Finance

Flexible, accessible finance solutions.

At Mercedes-Benz Finance we have a number of finance options you can choose from to suit your business needs, because we understand the complexities of running a modern-day business...

Agility (Personal Contract Plan)

Agility gives you flexibility and freedom to choose. You can purchase, return or part exchange your vehicle at the end of the agreement.

- Choose the term of your agreement and pay a deposit
- Pay monthly payments throughout your agreement
- Decide if you'd like to purchase your vehicle, return it, or part exchange it for a new one
- If you decide you want to keep it, you'll need to pay the Optional Purchase Payment and Purchase Activation Fee which means you'll then own your vehicle outright.

Hire Purchase

A great choice if you want to own the vehicle at the end of your agreement.

- Choose the amount that you'd like to put down as a deposit
- Decide how long the term of the agreement should be (this could be from 24 to 60 months)
- Pay monthly payments throughout your agreement.

Operating Lease

Drive one of our vehicles over a fixed term, with lower monthly payments and without the commitment of ownership.

- Pay an advance rental at the start of your agreement
- You'd only repay part of the vehicle's value, keeping your monthly rentals low
- At the end, you can either return your vehicle to us, or sell to an unconnected third party.

Own Hire



Deposit Monthly repayments Choice of 3 options

Own



Deposit Monthly repayments Own your vehicle

Hire



Monthly rentals Return your vehicle

Mercedes-Benz Finance

Contract Hire

Gives you the ability to enjoy driving a Mercedes-Benz including the cost of the Vehicle Excise Duty without having to take on full ownership.

- Pay an advance rental at the start of your agreement
- You'd only repay part of the vehicle's value, keeping your monthly rentals low
- Just make these payments until your agreement comes to an end.

Finance Lease

You hire your vehicle for a fixed amount of time without owning it, and it's shown as an asset on your balance sheet.

- Choose the length of your agreement and pay an agreed amount up front. You then continue with monthly rentals throughout your agreement
- Set a balloon payment, which is paid as a lump sum at the end of your agreement and lowers your monthly rentals.



Ask your local Dealer for more information about our finance options

Terms and Conditions Vehicle and option availability and combinations may be subject to change since this price list was issued. Model and option List Price are quoted ex-factory and exclude VAT unless otherwise stated. A standard delivery charge of £600 excluding VAT will be added to model prices quoted in this price list. All model prices include standard finish paint choice. The right is reserved to alter specification and vary prices without notice. The availability of options may depend on the chosen base vehicle and other optional equipment specified, and should be confirmed with your Mercedes-Benz Dealer prior to order placement. Mercedes-Benz Vans UK Ltd, Tongwell, Milton Keynes, MK15 8BA